

# Operation Manual

Arka



**WARNING**

Be sure to read this Operation Manual before use.

**UNIS**

Universal Space Amusement Equipment Ltd.

## CONTENTS

1.	The company.....	2
2.	Specifications.....	3
3.	Package Contents.....	5
4.	Installation, Fix and Transport.....	6
5.	Connecting the power cord and grounding.....	8
6.	Game play instruction.....	10
7.	Setup and Book.....	10
8.	Operation.....	13
9.	For safety.....	16
10.	Overall Construction.....	18

Addendum

I/O chart

Wiring Diagram

## **1. The company**

Thank you for purchasing the amusement Machine our company produce. Our company was found in 1993, it developed on and on and now it has rich human and material resources, it has been become a multiple-producing corporation that combine development, production, sale, management, service after selling. “Quality wins first, customer comes first and service wins first” is the company’s principles to go by and promise to customer.

**The following safety precautions and advisories are used throughout this manual and are defined as follows.**



### **WARNING**

Disregarding this text could result in serious injury.



### **Caution**

Disregarding this text could result in damage to the machine.



### **Notice**

An advisory text to hint or help understanding.

## 2. Specifications



This machine is beautiful outlook design and interesting exciting. This machine's outline border is made from glass-fiber, it looks very good and amusing. The control of this game is very easy, you just need to insert coin, and the machine begin to swing with the background music that it's OK now. If you press different animal button, the animal which in the house will move and play out the special sounds.

**2.1 Rated power supply:** AC “220V~240V” 50/60Hz

(Note: As the actual voltage, please refer the label of the machine.)

**2.2 Power consumption:** Min 25W, Max 400W

**2.3 Dimensions:** W780×D1780×H1760 (mm)

**2.4 Weight:** About 110kg

**2.5 Environment Condition:** Temperature(indoor): -10°C ~ +40°C

Humidity: ≤90% Atmospheric pressure: 86Pa ~ 106Pa



### 3. Package contents

#### 3.1 Body Assembly:

- Make sure that all the parts shown below are included in product package.

- If any parts are missing, contact your distributor.

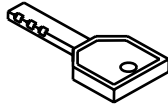
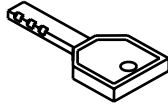
#### 3.2 Accessories:

No.	Component	Specification	Illustration	Note
1	Operation Manual	ENGLISH		
2	Key	2233		key for service door or coin chute door
		2222		key for coin door
3	Relay	LIRRD-LLY2/DC12V		
4	Lamp	12/3w		

## 4. Installation, Fix and Transport

### 4.1 Installation:



**WARNING**

**For indoor use only!**

1. The machine installation position must smooth indoor make sure that the machine position is level.
2. Plug the electrical outlet into the A.C sock with the correct power configuration.
3. Insert coin the game start, and the machine begin to swing left to right and right to left, at the same time pay out some admire music, the felling just as you are sailing.
4. The machine running according with the coin(s) that you had inserted, it will run continue when you insert coin again.
5. Cut off the power when no use in a long time.

### Play zone:

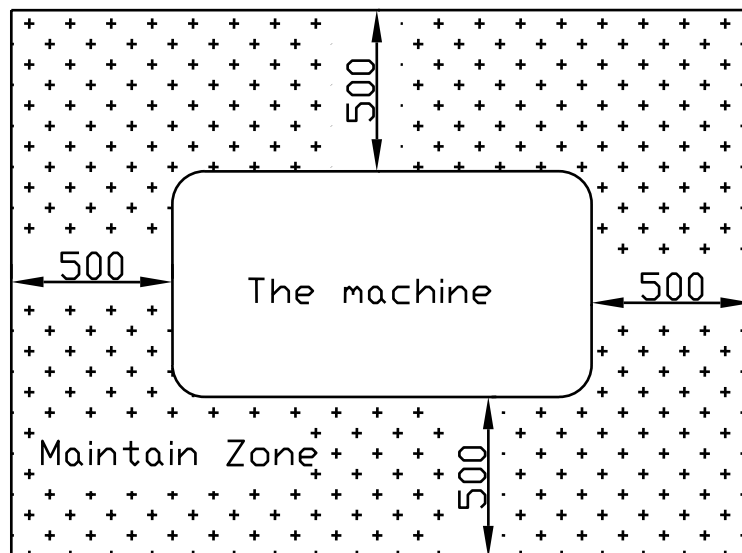

## 4.2 Locations to avoid installing:



### **WARNING**

This machine is designed for indoor only. Never install this machine Outdoor or at any of the following:

- Locations exposed to direct sunlight.
- Locations subjected to rain or water leakage.
- Damp, dust or hot place.
- Do not place close to a heating instrument.
- Unstable locations or locations subject to vibration.

## 4.3 Lifting and delivery of the machine

The bedplate of the machine is provided with two wheels in its rear side. On a level surface the machine can be moved by using a trolley.

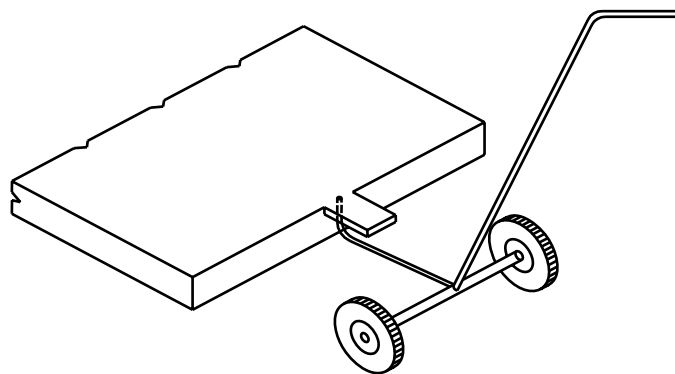



## 4.4 Moving and transporting



### WARNING

- Be careful not to damage the machine during transport.
- Do not give a shock to the molded parts. These parts are fragile.
- Be careful not to give a shock to the machine when bringing it down from a higher level.
- Unplug game before moving.
- Do not lay game on side during transport.

## 5. Connecting the power cord and grounding

### 5.1 The collection

1. Insert the plug of power cord into the power socket of the machine.
2. Insert the power cord plug into a service outlet.

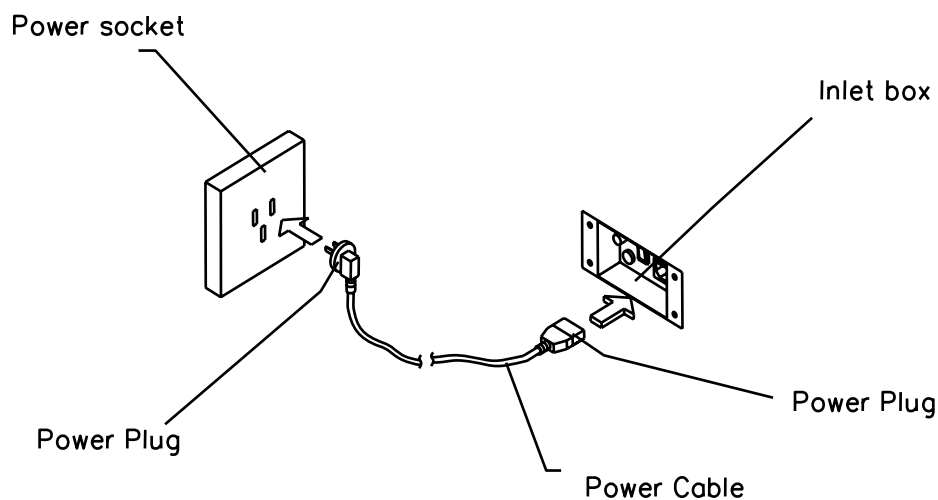



## WARNING

Be sure to connect the ground wire before turn on the machine.  
Failure to connect the ground wire could result in electric shock if power occurs.

### 5.2 Warning

Do not put heavy items on power cord

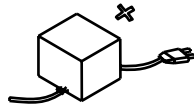

Do not touch the power plug with a wet hand.

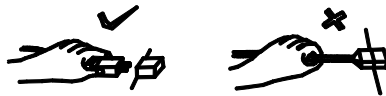

Do not draw or twist the cord.

Do not place the cord near a heat source.

Do not place the cord where the player can easy to touch or kick.

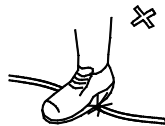

Run this machine with the correct power configuration.

## **6. Game Play Instruction**

1. Insert coin the game start, and the machine begin to swing left to right and right to left, at the same time pay out some admire music, the felling just as you are sailing.
2. There are 8 buttons in the play board. Each button deputy an animal. Press the button, the animal in the house will play out a special sounds and send out an English sentence. The children may learn the words in the game.



## **7. Setup and Book**

### **7.1 The function button**

Open the coin door and there is two buttons for the function.

Press the service button and enter the service situation, which will play a time and the coin counter do not run.

Press the test button to enter the test situation. The function of the button is to test the contents of the Input or Output.

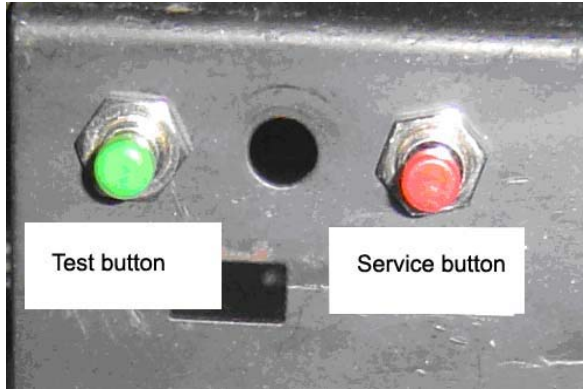

### 7.2 DIP Adjustment

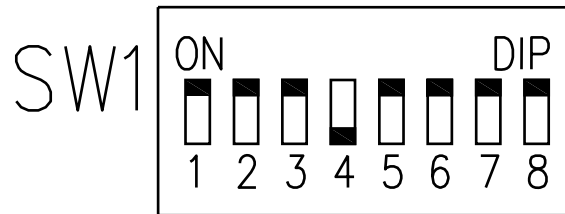

**Note: Game parameters are subject change without notice**

Item	Content	DIP SW							
		SW11	SW12	SW13	SW14	SW15	SW16	SW17	SW18
Coin	1	ON	ON						
	2	off	on						
	3	on	off						
	4	off	off						
Time	45S			on	on	on			
	60S			off	on	on			
	75S			ON	OFF	ON			
	90S			off	off	on			
	120S			on	on	off			
	150S			off	on	off			
	180S			on	off	off			
240S			off	off	off				
Demo Music	On						ON		
	Off						off		
Demo Act	On							ON	
	Off							off	

1. Coin: To set up how many coins for one credit.
2. Play time: To set up how many seconds for one game (one credit).
3. Demonstration Music: To set up when no one playing, the machine send out the music itself.
4. Demonstration Act: To set up when no one playing, the machine will display itself.

### 7.3 The electric control box

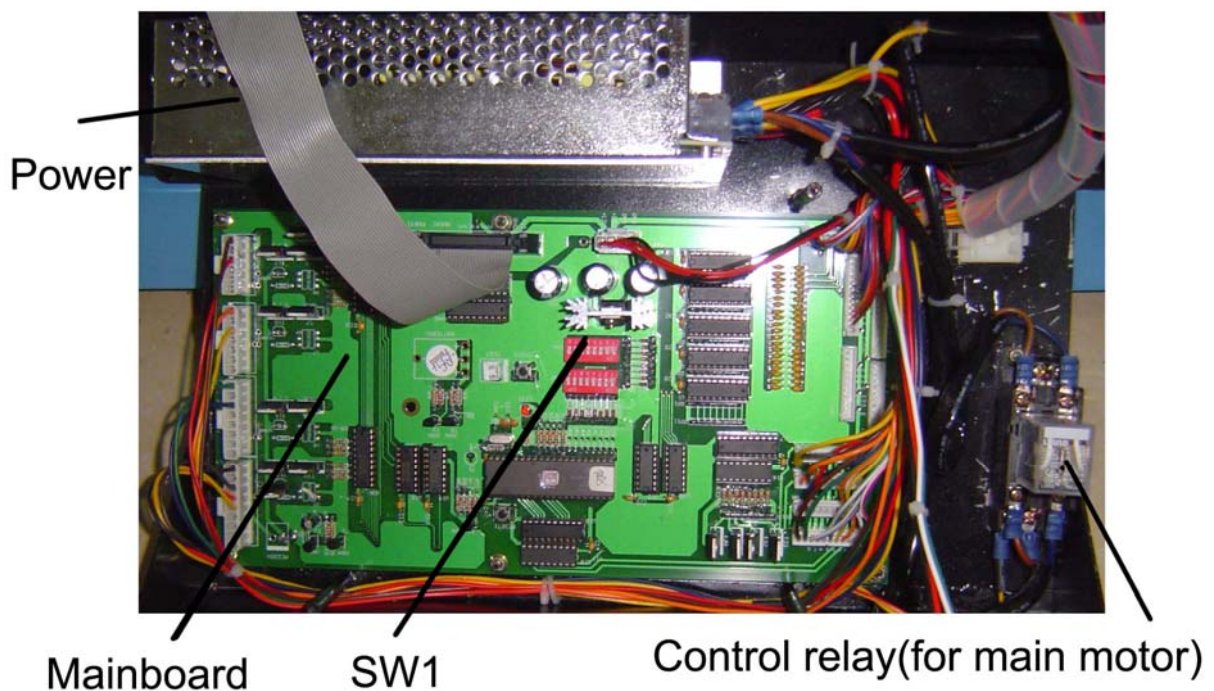

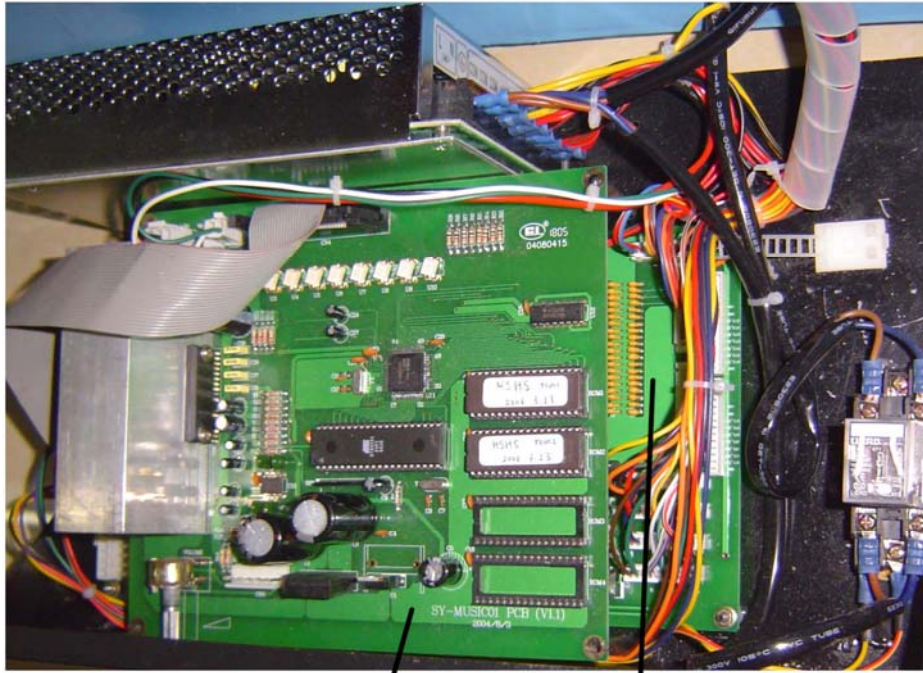

Music main board

Control main board

## 8. Operation

### 8.1 Maintenance of the machine

1. Check the machine before used in every day. If there have any hitch, please inform about it to the maintenance man.
2. Use a soft cloth to wipe the outline border's dust.
3. Check-up whether there is enough grease in the speed-down box in very month, if not, add the grease of 14# or add new grease after cleaned.
4. Add grease to the active parts, such as the rocking axle and gearing in every two weeks.

## 8.2 Trouble and settlement

Malfunction	Cause	Settlement
Stop running or Monitor off	<ol style="list-style-type: none"> <li>1. Not power</li> <li>2. Plug not in well touch</li> <li>3. The circuit was short</li> </ol>	<ol style="list-style-type: none"> <li>1. Power on.</li> <li>2. Plug on again.</li> <li>3. Check the circuit.</li> </ol>
Motor can't work	<ol style="list-style-type: none"> <li>1. The touch is not in good touch.</li> <li>2. The bearing was damage or lack in oil.</li> <li>3. The loop was break down</li> </ol>	<ol style="list-style-type: none"> <li>1. Clean or replace a new touch</li> <li>2. Replace a new bearing or supply.</li> <li>3. Join the wire.</li> </ol>
Lamp can't light on	<ol style="list-style-type: none"> <li>1. The lamp was burning out or was open circuit.</li> </ol>	<ol style="list-style-type: none"> <li>1. Replace a new lamp or check the circuit.</li> </ol>
The machine control failure	<ol style="list-style-type: none"> <li>1. The circuit was break down or the control parts were failure</li> </ol>	<ol style="list-style-type: none"> <li>1. Check the circuit or the control parts and maintain them.</li> </ol>
Noise	<ol style="list-style-type: none"> <li>1. The Fix parts of the machine were loosening.</li> <li>2. The bearing was damaged.</li> </ol>	<ol style="list-style-type: none"> <li>1. Screw it in tighten.</li> <li>2. Replace a new bearing.</li> </ol>

## 8.3 Operation Warning

★ Should a problem occur, switch OFF the power immediately and stop operating the machine. Then unplug the power cord the service outlet. Operating the machine without correcting the problem may cause a fire or accident.

★ Dust accumulated on the power plug may cause a fire. Check the plug regularly and remove any dust.

★ Insert the power plug securely into the service outlet. Poor contact may cause overheating, resulting in fire or burns.

★ Before operating the machine, always check that the machine has been installed according to the instructions and procedures in this Operation Manual. Failure to install correctly may result in a fire, electric shock, injury, or equipment malfunction.

★ The warning labels describe important safety precautions. Observe the points below.

★ To make sure that the warning labels attached to the machine are easily legible, install the machine in a well-lit location, and keep the labels clean at all times. Also make sure that the labels are not behind other game machines.

★ Do not remove to alter the warning labels.

★ If the warning labels become dirty or damaged, replace with new labels. To order replacement warning labels, contact your distributor.

★ Always turn off the power first to protect other personnel from electric shock, accidents and injury, and to prevent damage to electrical circuits.

★ If a fault occurs, first check that all the connectors are firmly connected.

★ Contact your distributor if none of the cases below applies to the problem, or if the action listed does not appear to resolve the problem.



## **9. For safety**

Please read the following points carefully before you install or inspecting the machine and ensure that the player can enjoy the game safety.

Turn power off before performing repairing and maintenance. Performing the work without turning power off can cause an electric shock or short circuit. When turn power on, please ensure that the power is suitable.

Choose suitable replacement. Unsuitable replacement can cause short circuit or harm the main-board and other circuit component.

Don't disassemble, assemble or change the machine without the specialized operator. Improper operations can cause short circuit, machine break down or fire.

Conform the manufacturer's requirements to moving, turn out or transportation the machine. Improper action can cause component damage and machine malfunctioning.

This product is an indoor game. Do not install it outside. Even indoor, avoid installing place mentioned below so as not to cause a fire, electric shock, injury and or malfunctioning.

### **Warning**

1. Do not make drain fan plugged up by something to avoid causing a fire.
2. Do not put thing on or damage power Cords to avoid causing a fire or

electric shock.

3. Do not pull or insert the plug quickly to avoid causing a fire or electric shock.

4. Do not pull or insert the plug when your hands are wet to avoid causing electric shock.

5. Be sure to use fuses meeting specified rating. Use fuses exceeding the specified rating can cause a fire or electric shock.

6. Do not make Specification changes by removing, converting and making additions to avoid causing a fire.

### **Paying attention to player**

1. To avoid injury and trouble, be sure to constantly give careful attention to the behavior and manner of the visitors and players.

2. To avoid electric shock and short circuit, Do not allow player to put hands and finger or extraneous matter of the product or small openings in or around the door.

3. To avoid falling down and injury resulting from falling down, immediately stop the player's leaning against or climbing on the product, etc.

4. To avoid electric shock and short circuit, do not allow the player to unplug the power plug without a justifiable reason.

5. To avoid injury resulting from down, and electric shock due to spilled drinks, instruct the player not to place heavy items or drinks on the product.

## 10. Overall Construction

### 10.1 Playfield

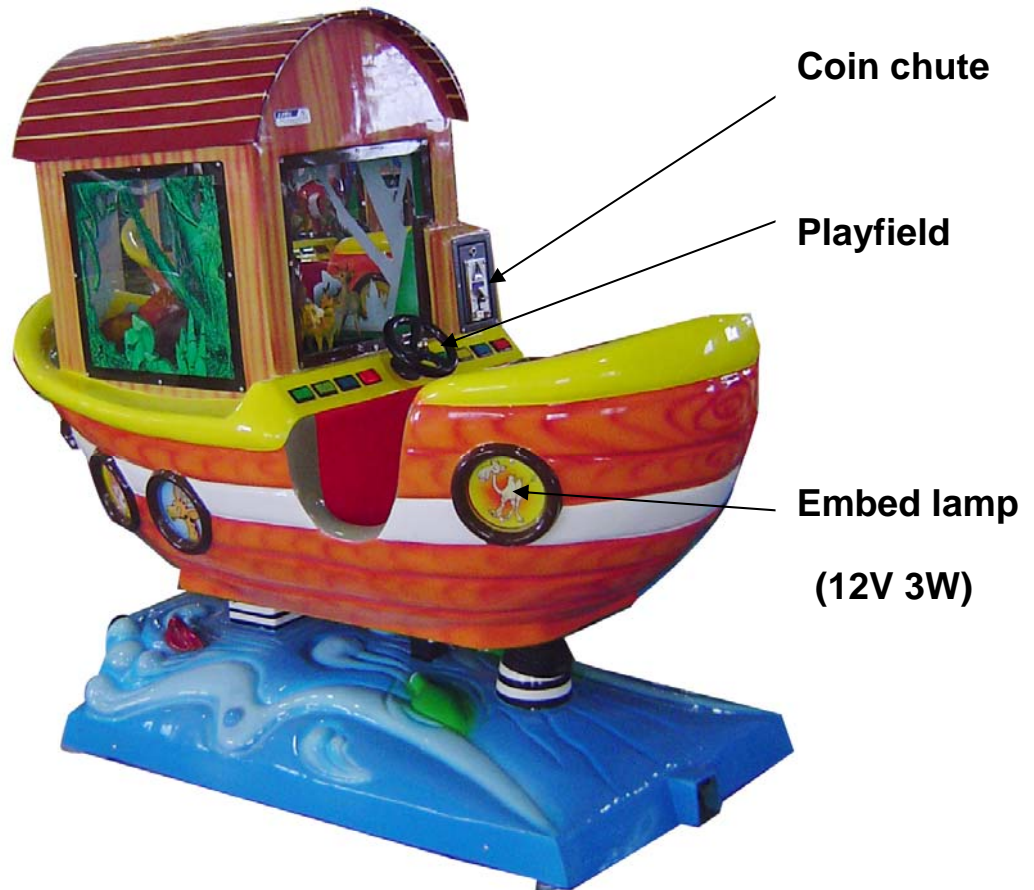

## 10.2 Body Assembly

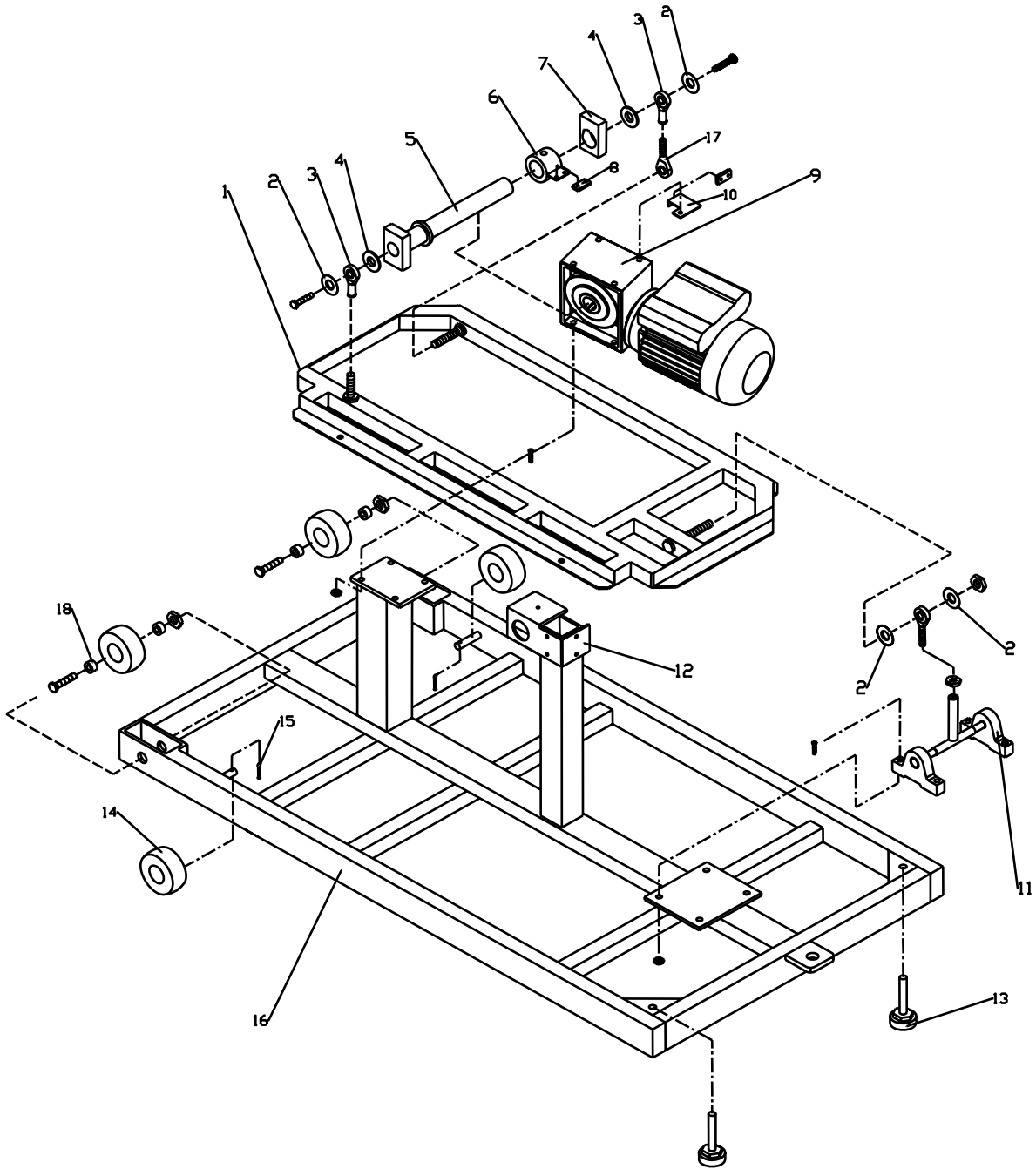

## 10.2 Body Assembly

NO.	Name	Qty	Specification	Note
10-2-1	Rocking Bracket	1		
10-2-2	Limit Block1	4		
10-2-3	Oscillating Bearing	2	(Inner gear)	
10-2-4	Limit Block2	2		
10-2-5	Excursion axis	1		
10-2-6	Reset Block1	1		
10-2-7	Excursion Block	1		
10-2-8	Magnetism SW	2		
10-2-9	Motor	1		
10-2-10	Reset Block2	1		
10-2-11	Bearing Base	2		
10-2-12	Connect Bracket	1		
10-2-13	Adjuster	2		
10-2-14	Castor	4		
10-2-15	Pin	2		
10-2-16	Base Board	1		
10-2-17	Oscillating Bearing	1	(External gear)	
10-2-18	Block	4		